

NOTES:

1. ALL DIMENSIONS FOR REFERENCE ONLY
2. REFER TO AIR LOGIC'S #10-32 INTERFACE & SEAL GUIDE
3. REFER TO AIR LOGIC'S POLYSULFONE APPLICATIONS GUIDE
4. TUBE RETENTION PRESSURE SUBJECT TO TUBING DIMENSION AND STIFFNESS

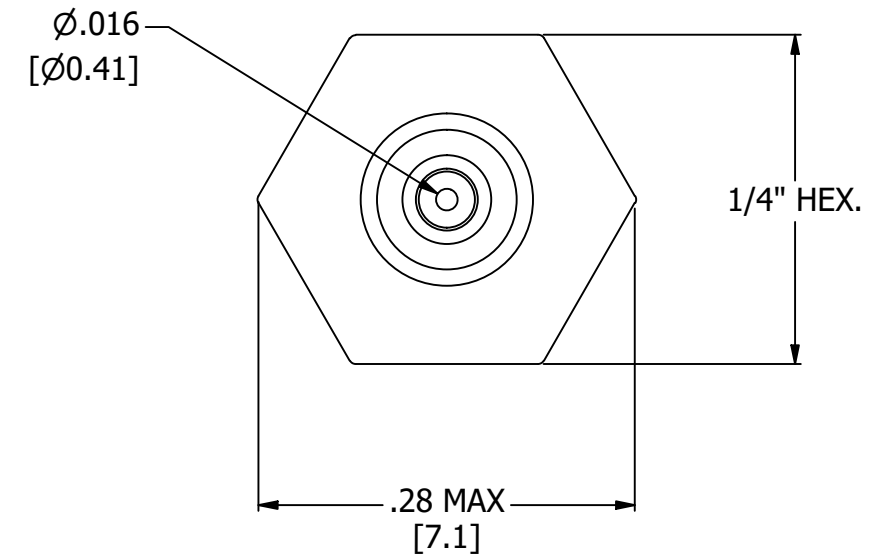
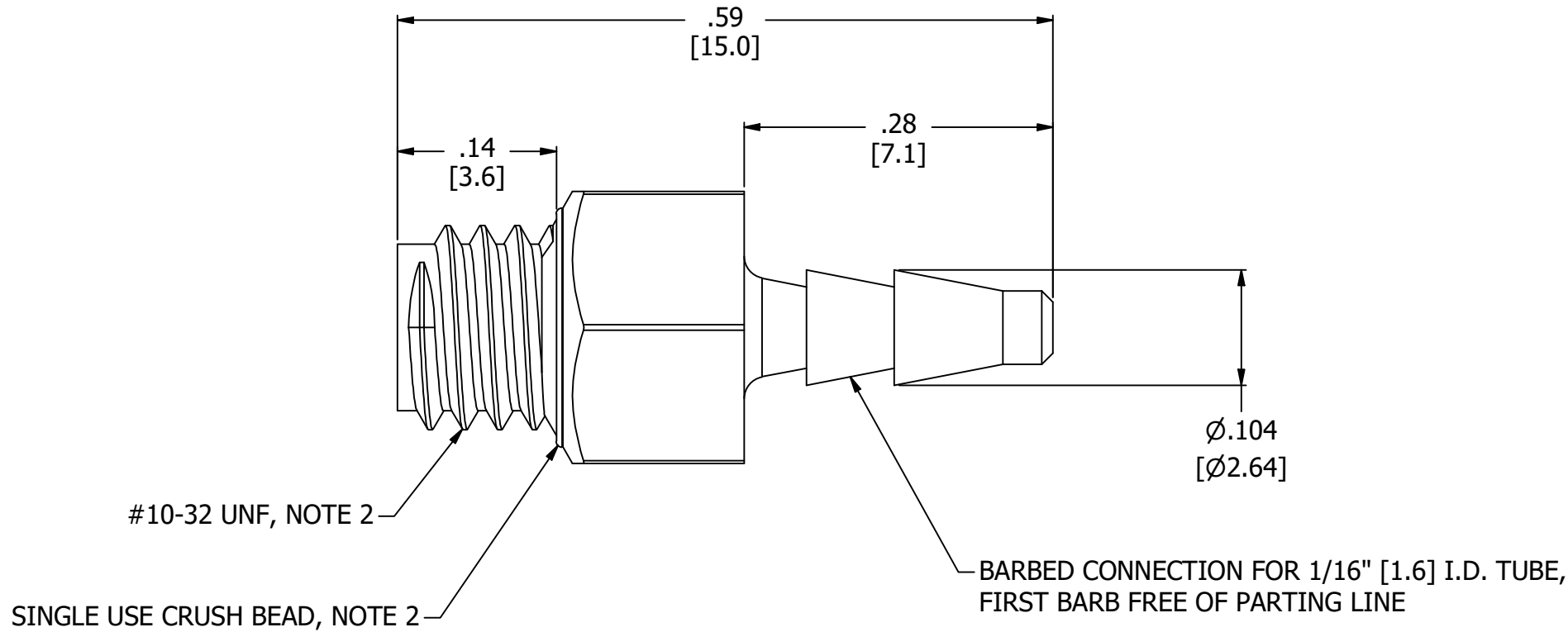
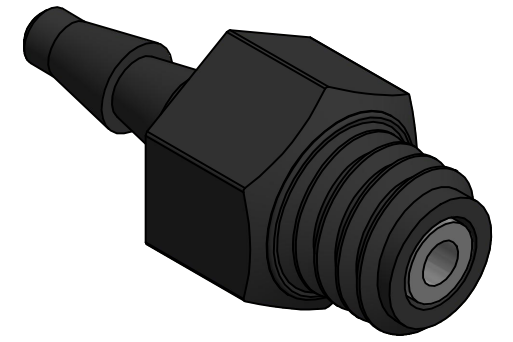

PRODUCT SPECIFICATIONS

COLOR(S)	BLACK, GRAY
MEDIA	GASES, LIQUIDS, NOTE 3
MAX INLET PRESSURE	125 PSI, [8.6 BAR]
TYPICAL TUBE RETENTION PRESSURE	125 PSI, [8.6 BAR], NOTE 4
FLOW COEFFICIENT (Cv)	0.007
NOMINAL ORIFICE DIAMETER	Ø.016 [Ø0.41]
WETTED MATERIALS	POLYSULFONE
RECOMMENDED SYSTEM FILTRATION	43 MICRON



AIR-LOGIC @ DIVISION OF KNAPP MFG, INC.
 5102 DOUGLAS AVE RACINE, WI 53402
 PHONE: (262) 639-9035 FAX: (262) 639-5996 WEB: AIR-LOGIC.COM

PART/DRAWING NO.:

F3120161B80

DESCRIPTION:
 THREADED ORIFICE, Ø.016, #10-32 X 1/16" BARB

REVISION: A	DRAWN: 3/2/2021
SCALE: 7 : 1	SHEET SIZE: B

TERMS OF USE:
 THIS DRAWING IS FOR INFORMATIONAL PURPOSES ONLY. AIR LOGIC MAKES NO REPRESENTATIONS OF WARRANTIES CONCERNING SUITABILITY FOR ANY PARTICULAR PURPOSE. ALL PRODUCTS SUPPLIED ARE SUBJECT TO TERMS AND CONDITIONS FOUND AT AIR-LOGIC.COM

DRAWING TAKES PRECEDENCE OVER 3D MODEL GEOMETRY
 TOLERANCE: DECIMALS .00 ± .01, .000 ± .005, FRACTIONS ± 1/64
 ANGLES 1/4° UNLESS OTHERWISE SPECIFIED
 UNITS: INCHES [MILLIMETERS]