

NOTES:

1. ALL DIMENSIONS FOR REFERENCE ONLY
2. TUBE RETENTION PRESSURE SUBJECT TO TUBING DIMENSION AND STIFFNESS
3. PANEL NUT UNASSEMBLED AS DELIVERED

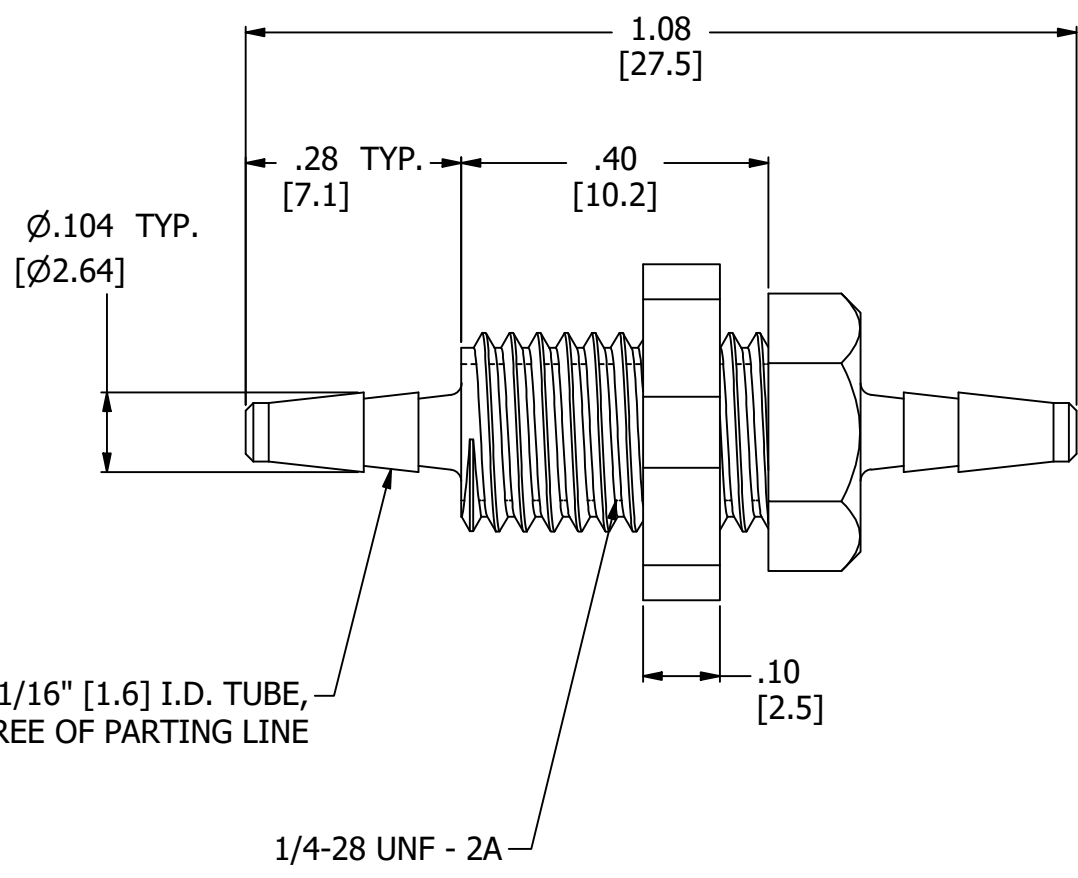
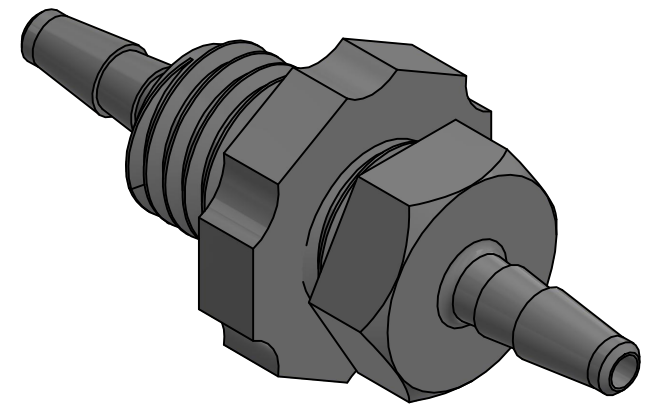

BARBED CONNECTIONS FOR 1/16" [1.6] I.D. TUBE, FIRST BARB FREE OF PARTING LINE

1/4-28 UNF - 2A

SUPPLIED PANEL NUT, FINGER TIGHT ONLY, NOTE 3

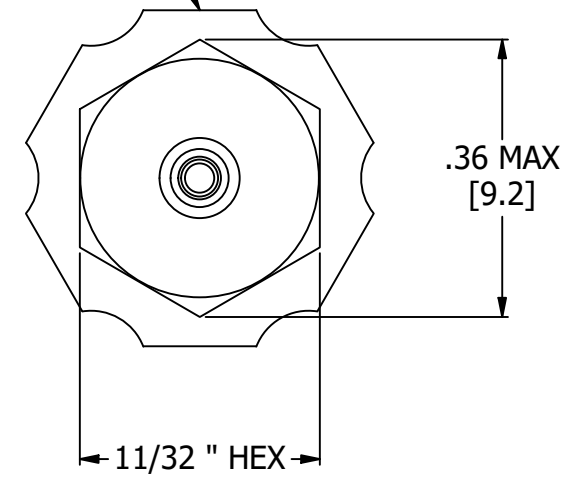

PRODUCT SPECIFICATIONS

COLOR	LIGHT GRAY
MEDIA	GASES, LIQUIDS
MAX INLET PRESSURE	125 PSI, [8.6 BAR]
TYPICAL TUBE RETENTION PRESSURE	125 PSI, [8.6 BAR], NOTE 2
PANEL CLEARANCE HOLE	9/32"
MINIMUM INNER DIAMETER	Ø.045 [Ø1.14]
WETTED MATERIALS	GLASS FILLED POLYPROPYLENE

**AIR-LOGIC** @ DIVISION OF KNAPP MFG, INC.  
 5102 DOUGLAS AVE RACINE, WI 53402  
 PHONE: (262) 639-9035 FAX: (262) 639-5996 WEB: AIR-LOGIC.COM

PART/DRAWING NO.:  
**F310080PP**

DESCRIPTION:  
 POLYPROPYLENE BULKHEAD, 1/4-28 UNF, 1/16" X 1/16" BARBS

REVISION: A DRAWN: 2/25/2021  
 SCALE: 4 : 1 SHEET SIZE: B

TERMS OF USE:  
 THIS DRAWING IS FOR INFORMATIONAL PURPOSES ONLY. AIR LOGIC MAKES NO REPRESENTATIONS OF WARRANTIES CONCERNING SUITABILITY FOR ANY PARTICULAR PURPOSE. ALL PRODUCTS SUPPLIED ARE SUBJECT TO TERMS AND CONDITIONS FOUND AT AIR-LOGIC.COM

DRAWING TAKES PRECEDENCE OVER 3D MODEL GEOMETRY  
 TOLERANCE: DECIMALS .00 ± .01, .000 ± .005, FRACTIONS ± 1/64  
 ANGLES 1/4° UNLESS OTHERWISE SPECIFIED  
 UNITS: INCHES [MILLIMETERS]