

NOTES:

- 1. ALL DIMENSIONS FOR REFERENCE ONLY
- 2. TUBE RETENTION PRESSURE SUBJECT TO TUBING DIMENSION AND STIFFNESS

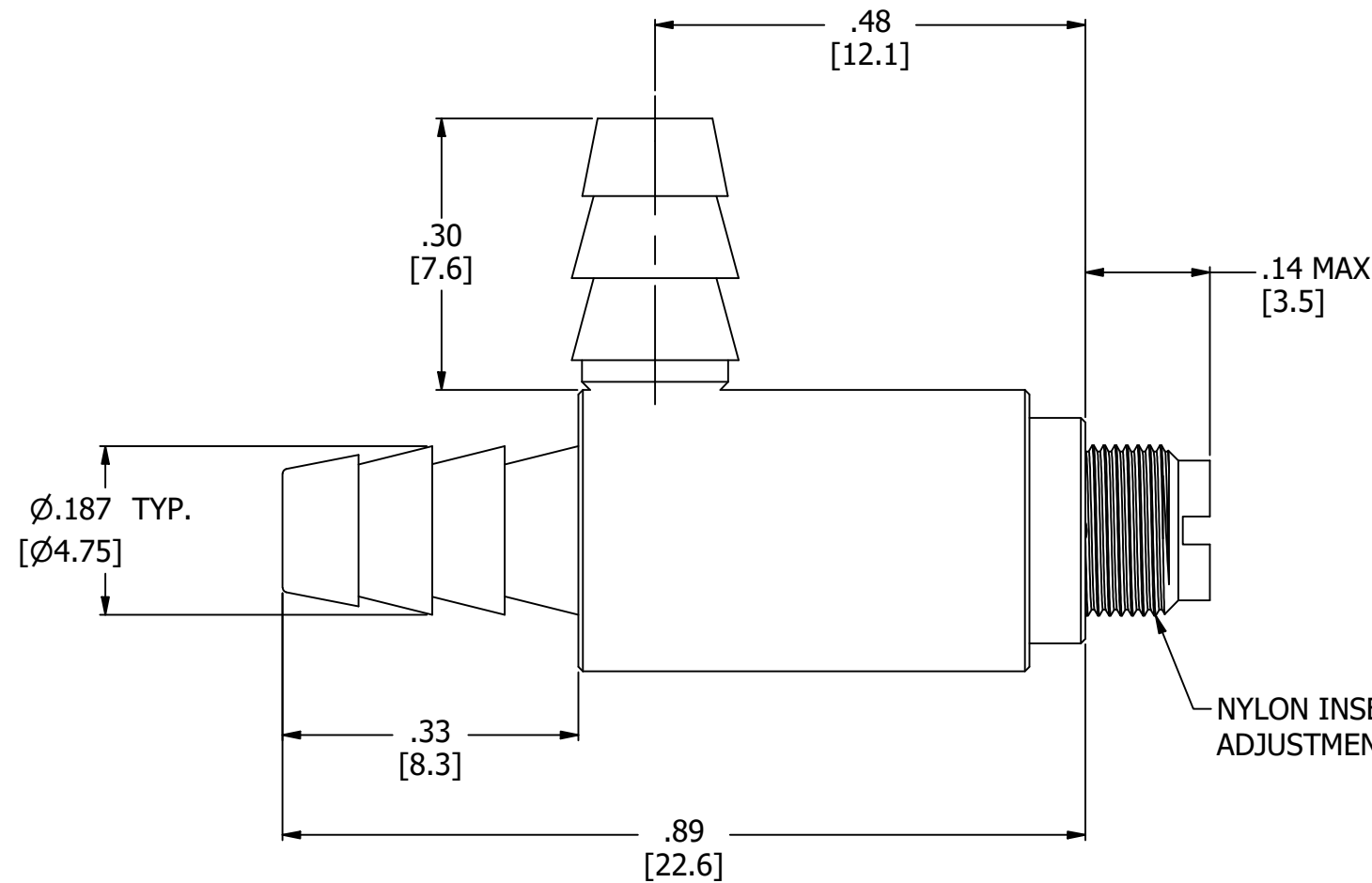

BARBED CONNECTIONS FOR 1/8" [3.2] I.D. TUBE

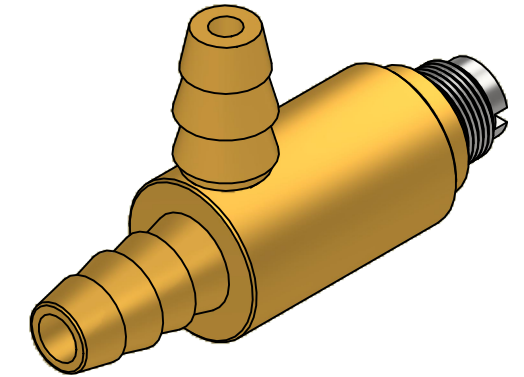
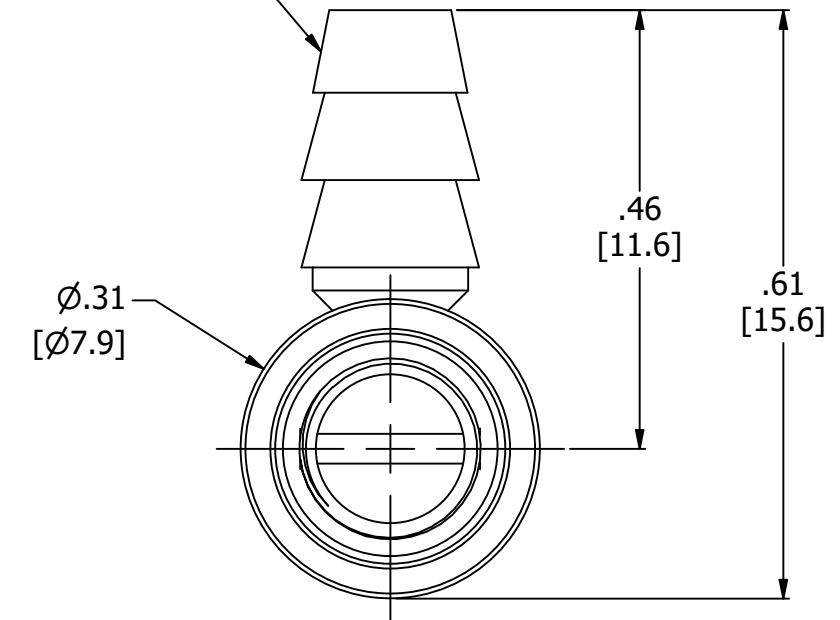

NYLON INSERT HELPS PREVENT ADJUSTMENT CAUSED BY VIBRATION

PRODUCT SPECIFICATIONS

COLOR(S)	BRONZE, STAINLESS STEEL
ADJUSTMENT METHOD	SCREWDRIVER ADJUSTED
THREAD PITCH	80 TPI
FLOW COEFFICIENT (Cv)	.0000133 - .0235
MEDIA	GASES, LIQUIDS
MAX INLET PRESSURE	125 PSI, [8.6 BAR]
TYPICAL TUBE RETENTION PRESSURE	125 PSI, [8.6 BAR], NOTE 2
MOUNTING STYLE	INLINE
WETTED MATERIALS	PHOSPHOR BRONZE, 303SS, BUNA-N
RECOMMENDED SYSTEM FILTRATION	5 MICRON



AIR-LOGIC @ DIVISION OF KNAPP MFG, INC.
5102 DOUGLAS AVE RACINE, WI 53402
PHONE: (262) 639-9035 FAX: (262) 639-5996 WEB: AIR-LOGIC.COM

PART/DRAWING NO.:

F282230B85

DESCRIPTION:
METAL NEEDLE VALVE, #10-80, 1/8" BARBS

REVISION: B

SCALE: 5 : 1

DRAWN: 2/24/2021

SHEET SIZE: B

TERMS OF USE:

THIS DRAWING IS FOR INFORMATIONAL PURPOSES ONLY. AIR LOGIC MAKES NO REPRESENTATIONS OF WARRANTIES CONCERNING SUITABILITY FOR ANY PARTICULAR PURPOSE. ALL PRODUCTS SUPPLIED ARE SUBJECT TO TERMS AND CONDITIONS FOUND AT AIR-LOGIC.COM

DRAWING TAKES PRECEDENCE OVER 3D MODEL GEOMETRY

TOLERANCE: DECIMALS .00 ± .01, .000 ± .005, FRACTIONS ± 1/64
ANGLES 1/4° UNLESS OTHERWISE SPECIFIED
UNITS: INCHES [MILLIMETERS]