

NOTES:

1. ALL DIMENSIONS FOR REFERENCE ONLY
2. REFER TO AIR LOGIC'S POLYSULFONE APPLICATION GUIDE
3. TUBE RETENTION PRESSURE SUBJECT TO TUBING DIMENSION AND STIFFNESS

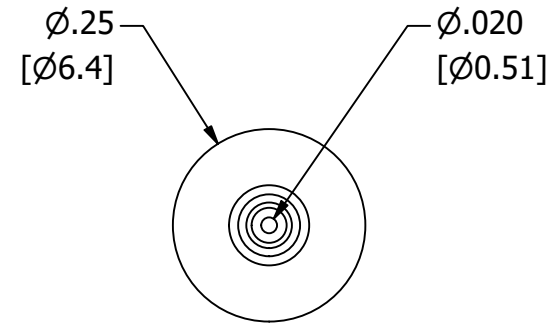

BARBED CONNECTIONS FOR 1/16" [1.6] I.D. TUBE,
FIRST BARB FREE OF PARTING LINE

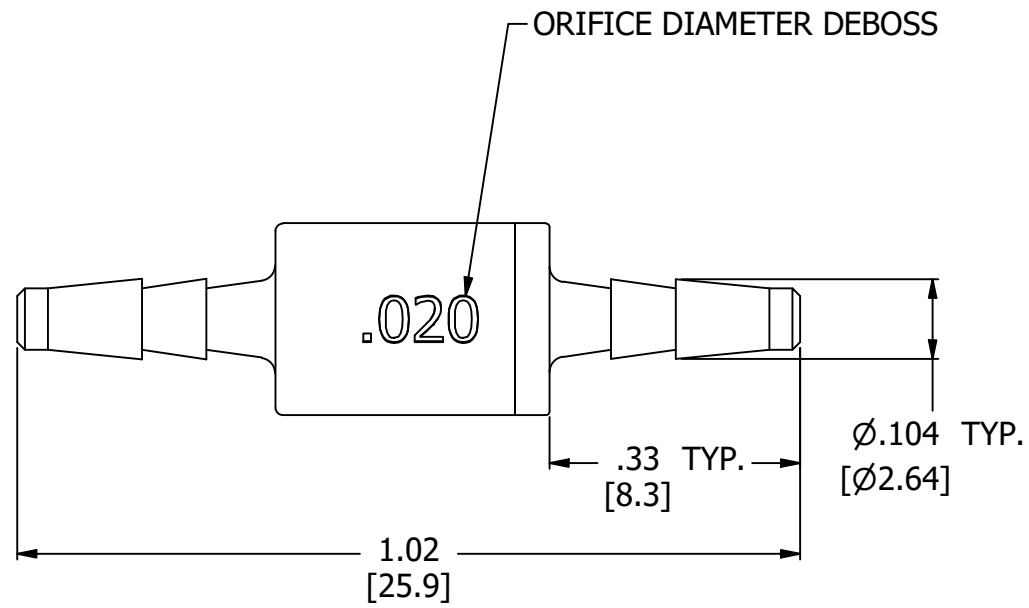
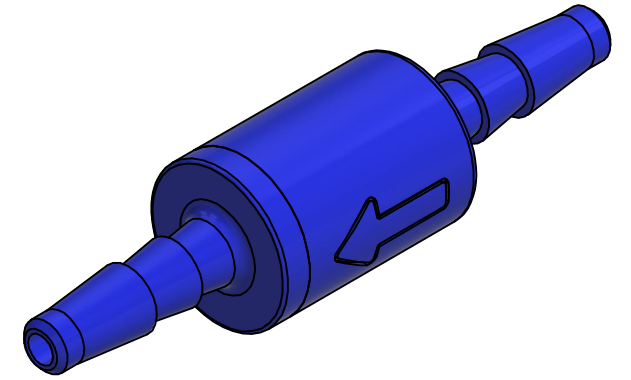
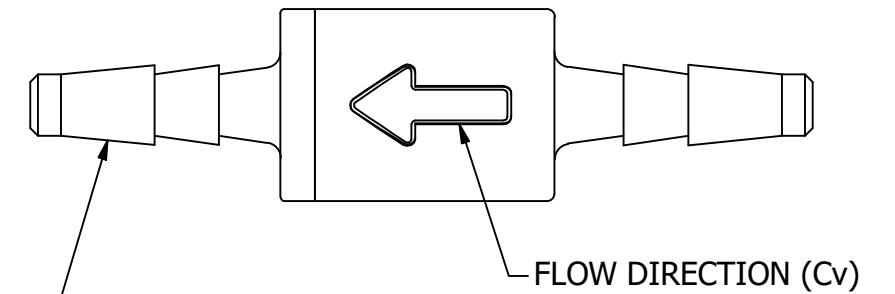

PRODUCT SPECIFICATIONS

COLOR(S)	BLUE
MEDIA	GASES, LIQUIDS, NOTE 2
MAX INLET PRESSURE	125 PSI, [8.6 BAR]
TYPICAL TUBE RETENTION PRESSURE	125 PSI, [8.6 BAR], NOTE 3
FLOW COEFFICIENT (Cv)	0.0114
NOMINAL ORIFICE DIAMETER	Ø.020, [Ø0.51]
WETTED MATERIALS	POLYSULFONE
RECOMMENDED SYSTEM FILTRATION	43 MICRON



AIR-LOGIC

5102 DOUGLAS AVE RACINE, WI 53402
PHONE: (262) 639-9035 FAX: (262) 639-5996 WEB: AIR-LOGIC.COM

PART/DRAWING NO.:

F2815201B80

DESCRIPTION:

Ø.020" ORIFICE RESTRICTOR, 1/16" BARBS

REVISION: B

SCALE: 4 : 1

DRAWN: 2/24/2021

SHEET SIZE: B

TERMS OF USE:

THIS DRAWING IS FOR INFORMATIONAL PURPOSES ONLY. AIR LOGIC MAKES NO REPRESENTATIONS OF WARRANTIES CONCERNING SUITABILITY FOR ANY PARTICULAR PURPOSE. ALL PRODUCTS SUPPLIED ARE SUBJECT TO TERMS AND CONDITIONS FOUND AT AIR-LOGIC.COM

DRAWING TAKES PRECEDENCE OVER 3D MODEL GEOMETRY

TOLERANCE: DECIMALS .00 ± .01, .000 ± .005, FRACTIONS ± 1/64
ANGLES 1/4° UNLESS OTHERWISE SPECIFIED
UNITS: INCHES [MILLIMETERS]