

- NOTES:
 1. ALL DIMENSIONS FOR REFERENCE ONLY
 2. REFER TO AIR LOGIC'S POLYSULFONE APPLICATION GUIDE
 3. TUBE RETENTION PRESSURE SUBJECT TO TUBING DIMENSION AND STIFFNESS
 4. GASES MUST BE CLEAN AND DRY

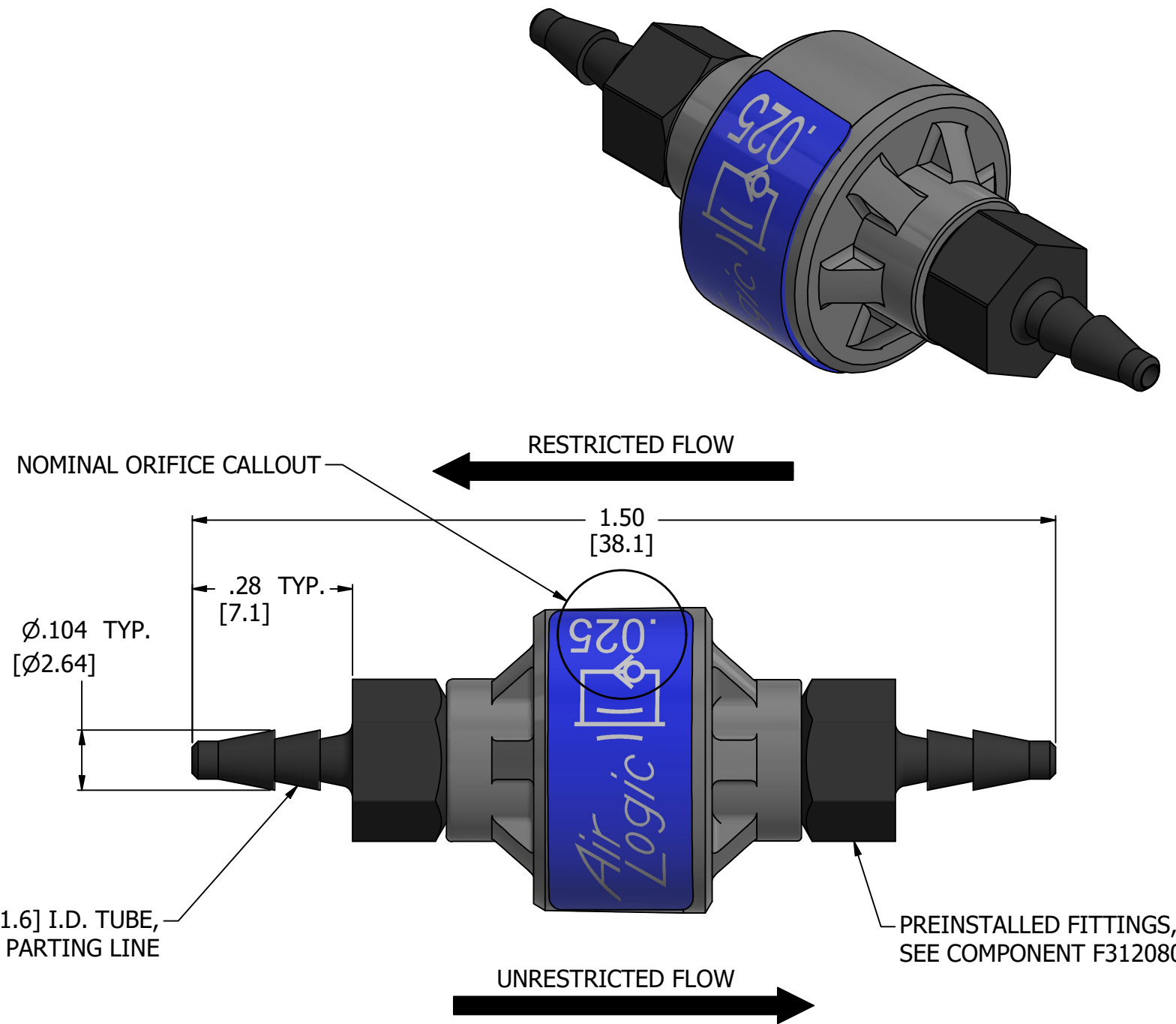
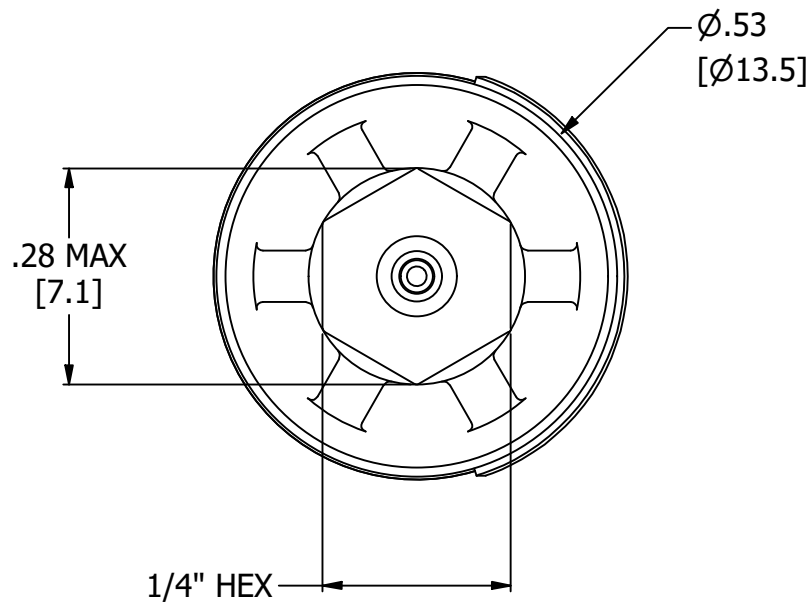

BARBED CONNECTION FOR 1/16" [1.6] I.D. TUBE,
 FIRST BARB FREE OF PARTING LINE

PRODUCT SPECIFICATIONS

COLOR	GRAY, BLUE, BLACK, BROWN
MEDIA	GASES, NOTE 2, NOTE 4
MAX INLET PRESSURE	75 PSI, [5.2 BAR]
TYPICAL TUBE RETENTION PRESSURE	125 PSI, [8.6 BAR], NOTE 3
NOMINAL ORIFICE SIZE	Ø.025, [Ø0.64]
WETTED MATERIALS	POLYSULFONE, SILICONE, NYLON
RECOMMENDED SYSTEM FILTRATION	5 MICRON



AIR-LOGIC @ DIVISION OF KNAPP MFG, INC.
 5102 DOUGLAS AVE RACINE, WI 53402
 PHONE: (262) 639-9035 FAX: (262) 639-5996 WEB: AIR-LOGIC.COM

PART/DRAWING NO.:

F2804404251B80

DESCRIPTION:
 DIRECTIONAL FLOW CONTROL, Ø.025, 1/16" BARB

REVISION: A	DRAWN: 2/24/2021
SCALE: 4 : 1	SHEET SIZE: B

TERMS OF USE:
 THIS DRAWING IS FOR INFORMATIONAL PURPOSES ONLY. AIR LOGIC MAKES NO REPRESENTATIONS OF WARRANTIES CONCERNING SUITABILITY FOR ANY PARTICULAR PURPOSE. ALL PRODUCTS SUPPLIED ARE SUBJECT TO TERMS AND CONDITIONS FOUND AT AIR-LOGIC.COM

DRAWING TAKES PRECEDENCE OVER 3D MODEL GEOMETRY
 TOLERANCE: DECIMALS .00 ± .01, .000 ± .005, FRACTIONS ± 1/64
 ANGLES 1/4° UNLESS OTHERWISE SPECIFIED
 UNITS: INCHES [MILLIMETERS]