

- NOTES:  
 1. ALL DIMENSIONS FOR REFERENCE ONLY  
 2. TUBE RETENTION PRESSURE SUBJECT TO TUBING DIMENSION AND STIFFNESS

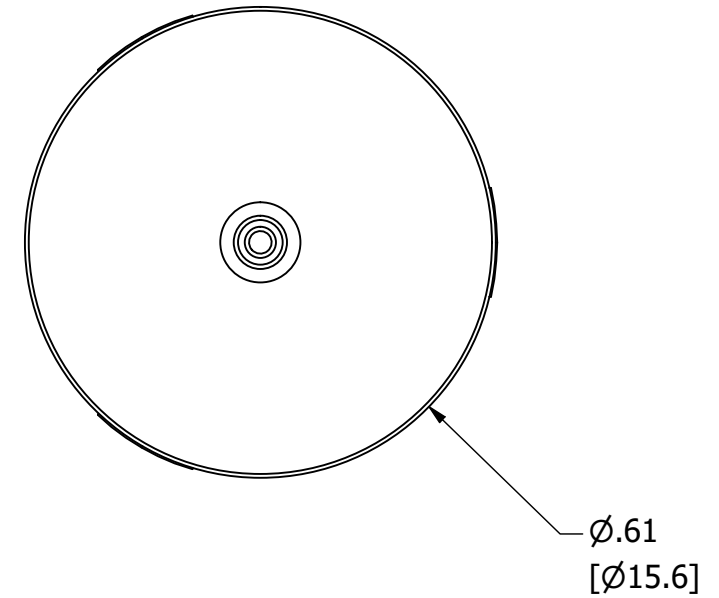

PRODUCT SPECIFICATIONS

COLOR(S)	NATURAL
CHECK VALVE TYPE	UMBRELLA, NORMALLY CLOSED
CRACKING PRESSURE	.75±.25 PSI
MEDIA	GASES, LIQUIDS
MAX PRESSURE	50 PSI
FORWARD FLOW AT 5 PSI	0.20 SCFM
REVERSE FLOW AT 1 PSI	LESS THAN .06 SCIM
TYPICAL TUBE RETENTION PRESSURE	75 PSI, NOTE 2
WETTED MATERIALS	POLYPROPYLENE, VITON
RECOMMENDED SYSTEM FILTRATION	5 MICRON

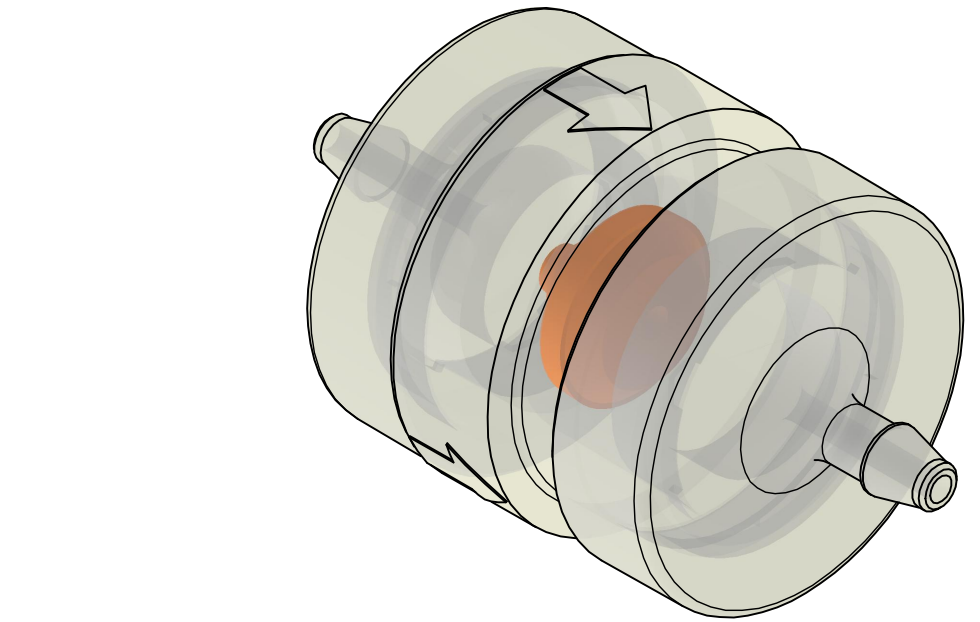
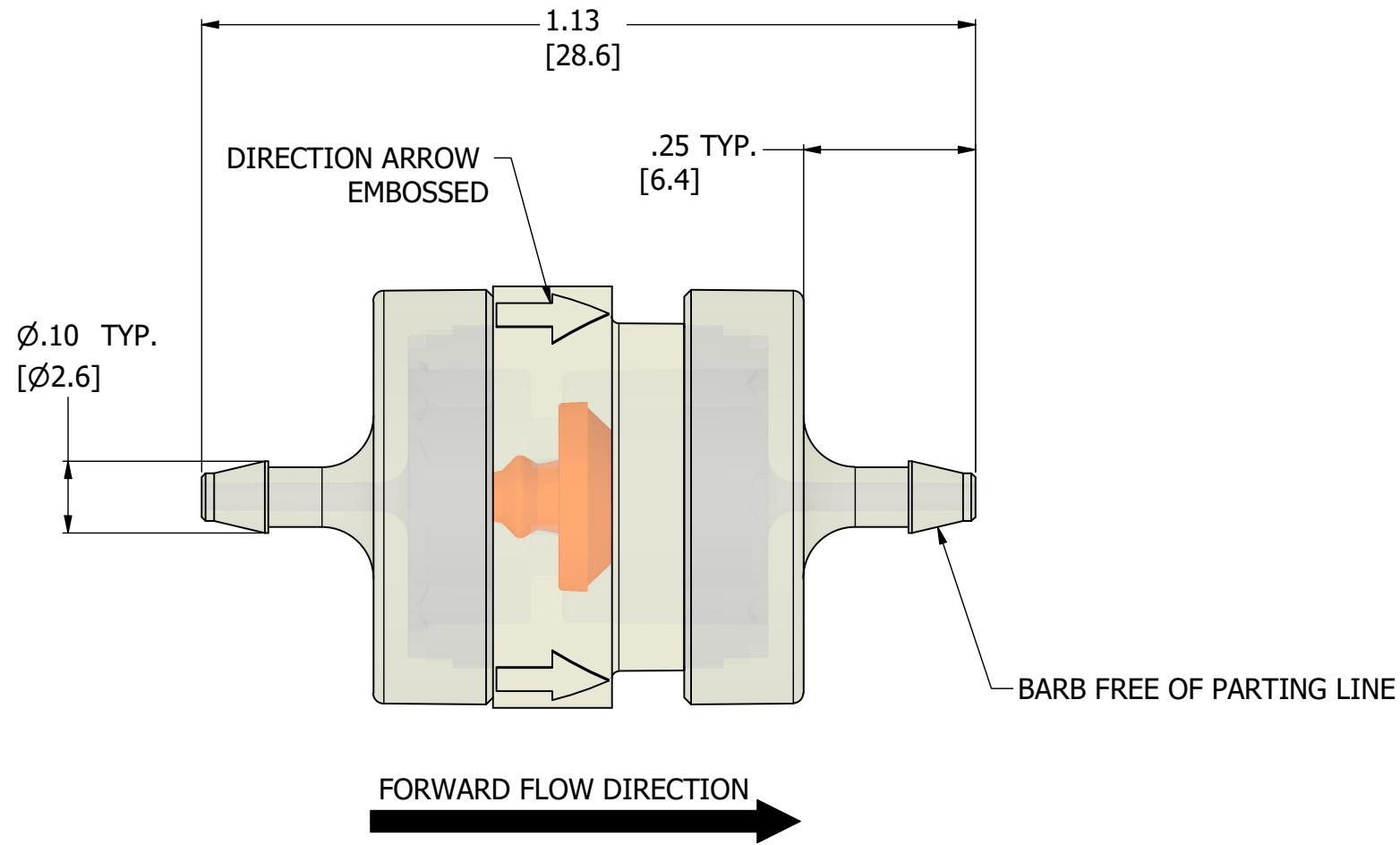

**AIR-LOGIC** @ DIVISION OF KNAPP MFG, INC.  
 5102 DOUGLAS AVE RACINE, WI 53402  
 PHONE: (262) 639-9035 FAX: (262) 639-5996 WEB: AIR-LOGIC.COM

PART/DRAWING NO.:

**F2804410075I0PPV**

DESCRIPTION:  
 .75 PSI CHECK VALVE, 1/16", POLYPROPYLENE, VITON

REVISION: A DRAWN: 2/9/2024  
 SCALE: 4 : 1 SHEET SIZE: B

TERMS OF USE:  
 THIS DRAWING IS FOR INFORMATIONAL PURPOSES ONLY. AIR LOGIC MAKES NO REPRESENTATIONS OF WARRANTIES CONCERNING SUITABILITY FOR ANY PARTICULAR PURPOSE. ALL PRODUCTS SUPPLIED ARE SUBJECT TO TERMS AND CONDITIONS FOUND AT AIR-LOGIC.COM

DRAWING TAKES PRECEDENCE OVER 3D MODEL GEOMETRY

TOLERANCE: DECIMALS .00 ± .01, .000 ± .005, FRACTIONS ± 1/64  
 ANGLES 1/4° UNLESS OTHERWISE SPECIFIED  
 UNITS: INCHES [MILLIMETERS]