

NOTES:

1. ALL DIMENSIONS FOR REFERENCE ONLY
2. REFER TO AIR LOGIC'S POLYSULFONE APPLICATIONS GUIDE
3. GASES MUST BE CLEAN AND DRY
4. TUBE RETENTION PRESSURE SUBJECT TO TUBING DIMENSION AND STIFFNESS

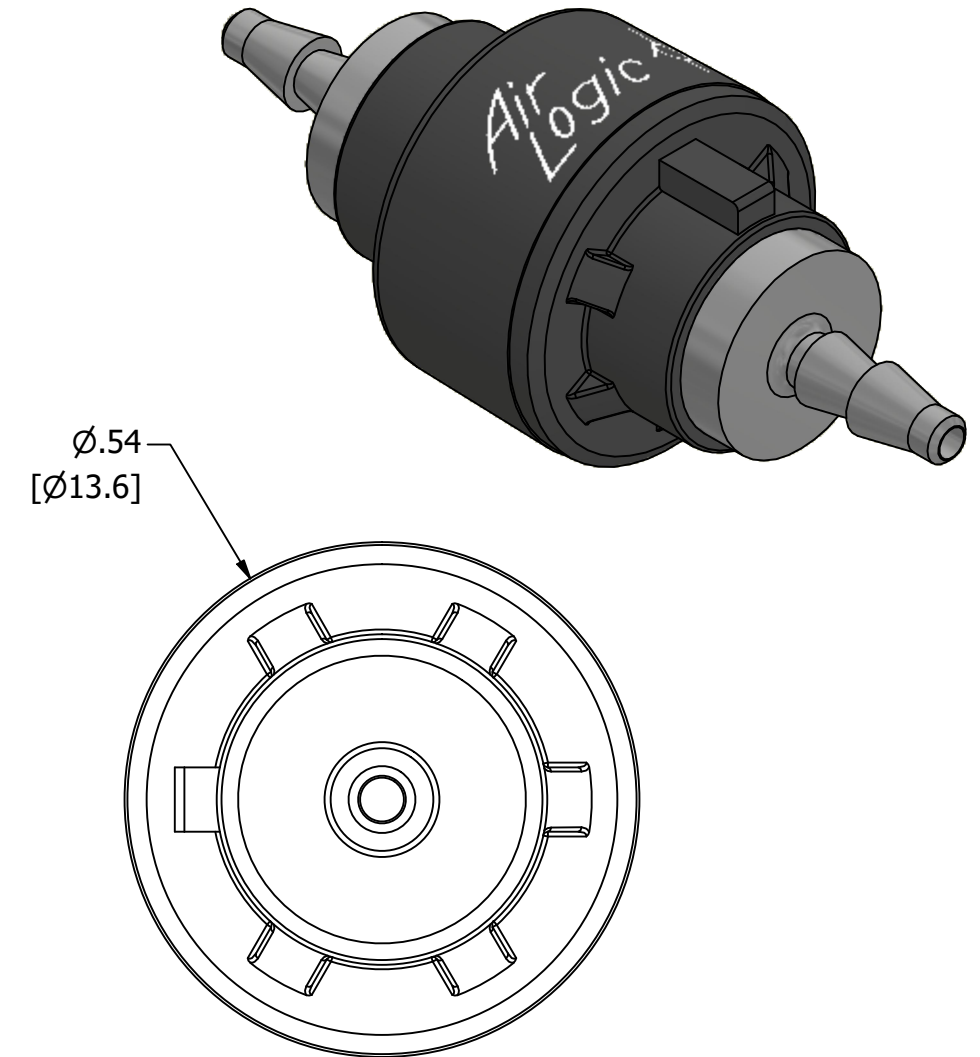
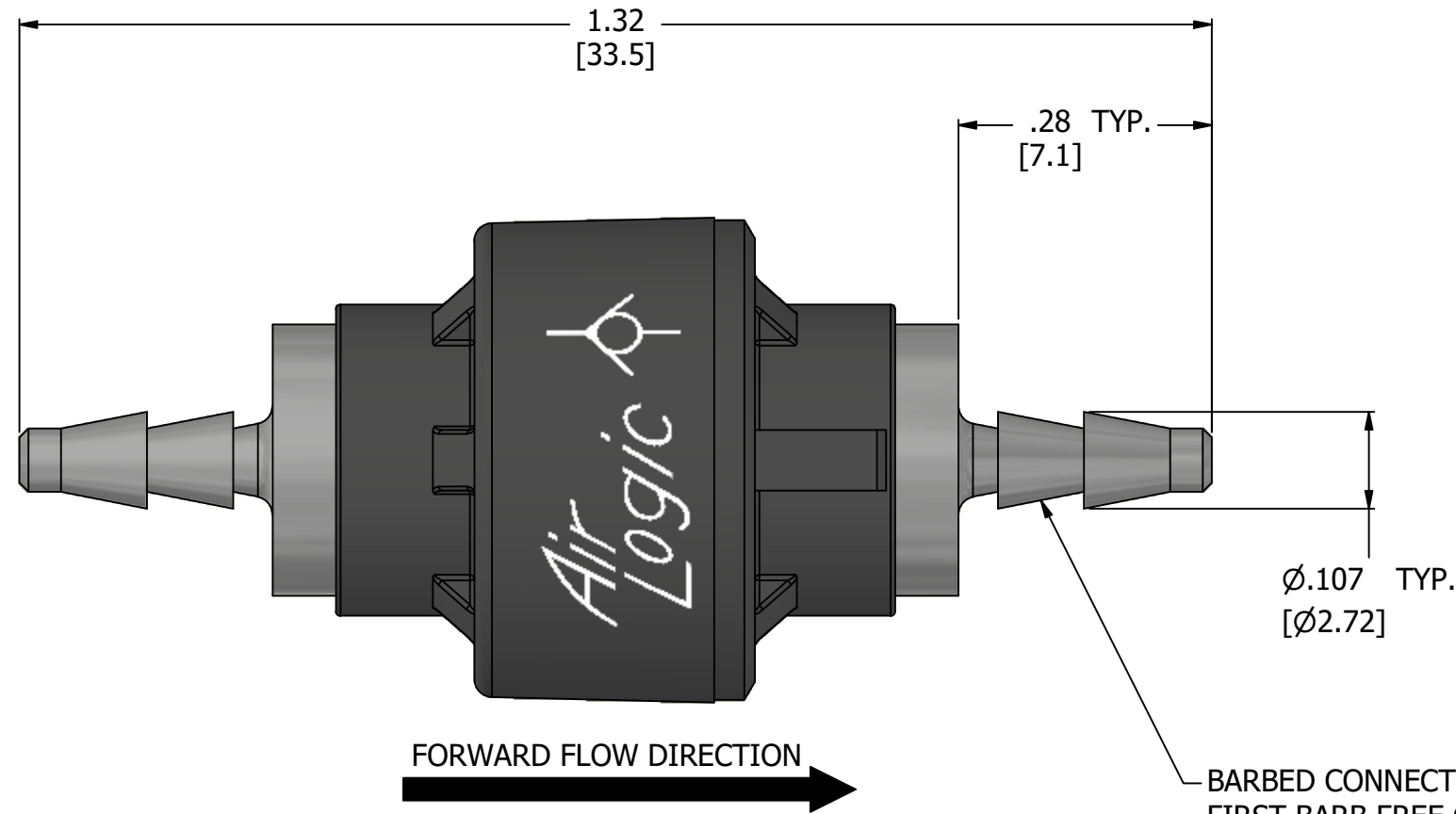

BARBED CONNECTIONS FOR 1/16" [1.6] I.D. TUBE, FIRST BARB FREE OF PARTING LINE

PRODUCT SPECIFICATIONS

COLOR(S)	BLACK, LIGHT GRAY
CHECK VALVE TYPE	FLOATING DISK
CRACKING PRESSURE	LESS THAN 10 inH ₂ O, [25 MILLIBAR]
FORWARD FLOW AT 75 PSI SUPPLY PRESSURE	2.0 SCFM, [56.6 SLPM]
REVERSE FLOW AT 1 PSI DIFFERENTIAL	LESS THAN 0.06 SCIM, [.98 SCCM]
MEDIA	GASES, NOTE 2, NOTE 3
MAX INLET PRESSURE	75 PSI, [5.2 BAR]
TYPICAL TUBE RETENTION PRESSURE	125 PSI, [8.6 BAR], NOTE 4
WETTED MATERIALS	POLYSULFONE, SILICONE
RECOMMENDED SYSTEM FILTRATION	5 MICRON



AIR-LOGIC @ DIVISION OF KNAPP MFG, INC.
 5102 DOUGLAS AVE RACINE, WI 53402
 PHONE: (262) 639-9035 FAX: (262) 639-5996 WEB: AIR-LOGIC.COM

PART/DRAWING NO.:

F2804404P80

DESCRIPTION:
 INLINE CHECK VALVE, PERMANENT 1/16" BARBS

REVISION: B	DRAWN: 1/19/2022
SCALE: 5 : 1	SHEET SIZE: B

TERMS OF USE:
 THIS DRAWING IS FOR INFORMATIONAL PURPOSES ONLY. AIR LOGIC MAKES NO REPRESENTATIONS OF WARRANTIES CONCERNING SUITABILITY FOR ANY PARTICULAR PURPOSE. ALL PRODUCTS SUPPLIED ARE SUBJECT TO TERMS AND CONDITIONS FOUND AT AIR-LOGIC.COM

DRAWING TAKES PRECEDENCE OVER 3D MODEL GEOMETRY
 TOLERANCE: DECIMALS .00 ± .01, .000 ± .005, FRACTIONS ± 1/64
 ANGLES 1/4° UNLESS OTHERWISE SPECIFIED
 UNITS: INCHES [MILLIMETERS]