

NOTES:

1. ALL DIMENSIONS FOR REFERENCE ONLY
2. REFER TO AIR LOGIC'S #10-32 INTERFACE & SEAL GUIDE
3. REFER TO AIR LOGIC'S POLYSULFONE APPLICATIONS GUIDE
4. GASES MUST BE CLEAN AND DRY

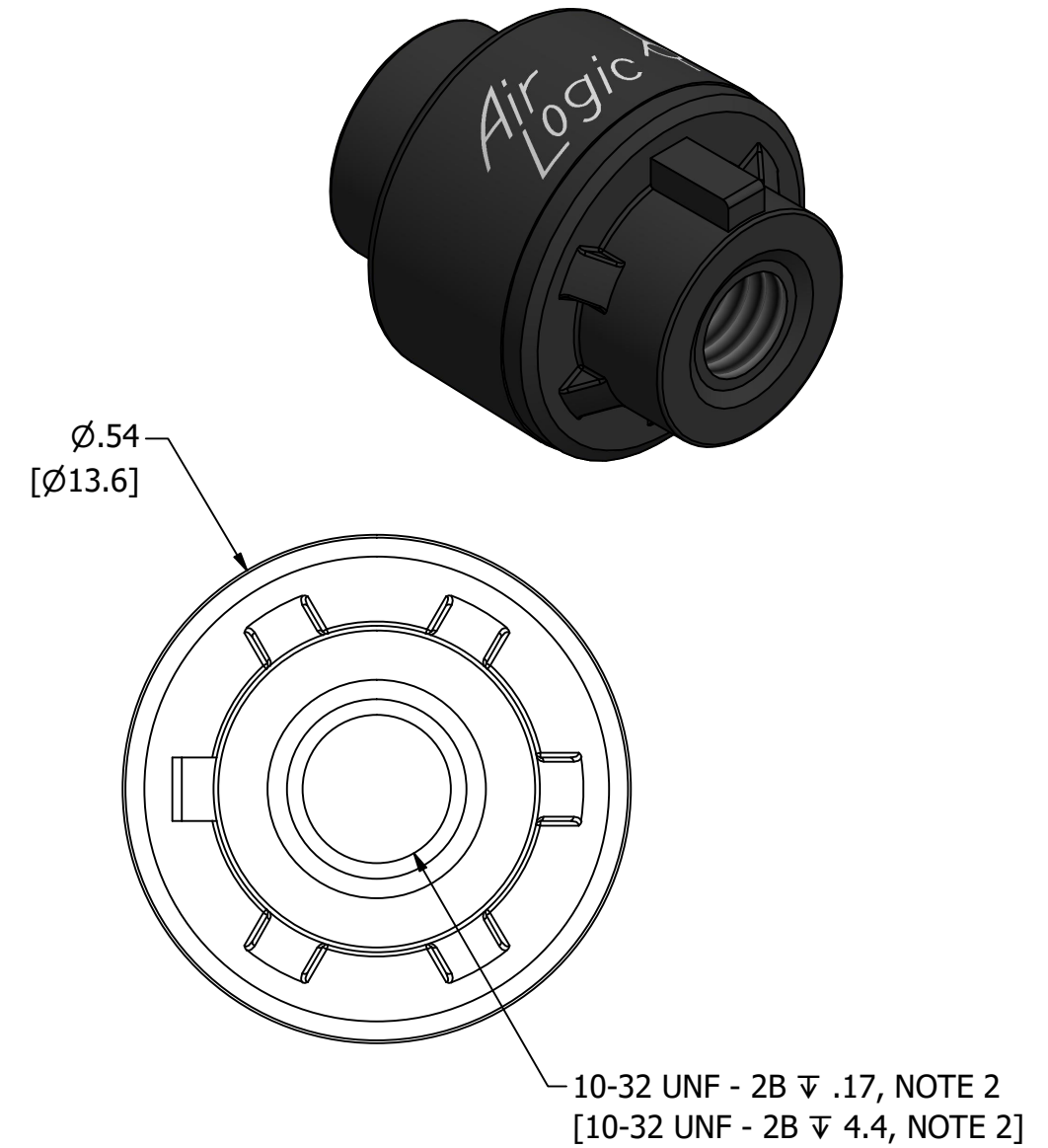
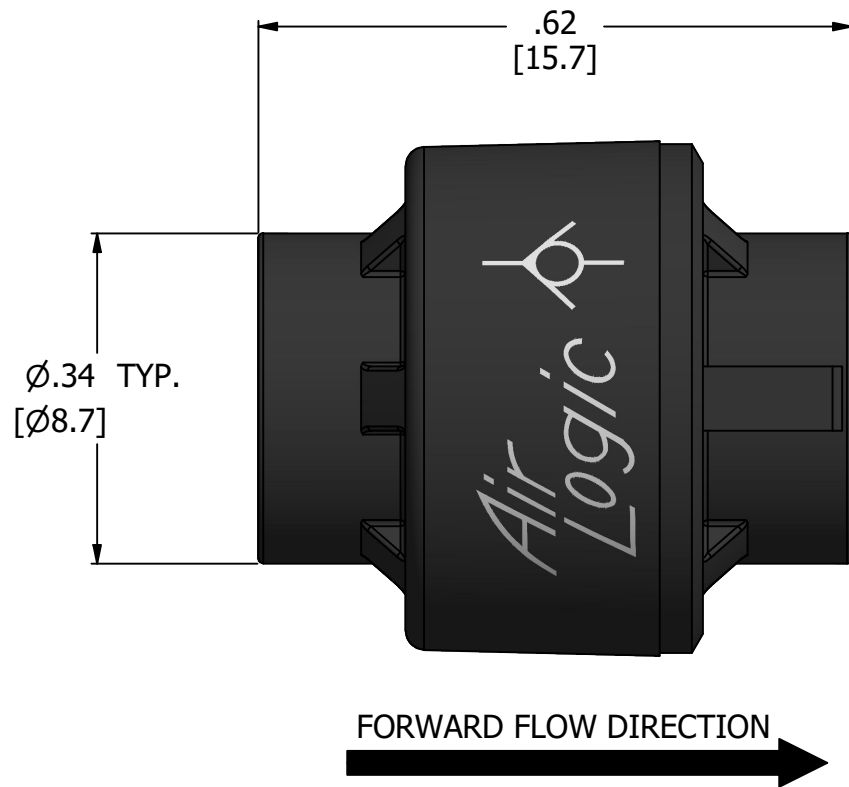

PRODUCT SPECIFICATIONS

COLOR(S)	BLACK HOUSING, WHITE PRINT
CHECK VALVE TYPE	FLOATING DISK
CRACKING PRESSURE	LESS THAN 10 inH ₂ O, [25 MILLIBAR]
FORWARD FLOW AT 75 PSI SUPPLY PRESSURE	2.0 SCFM, [56.6 SLPM]
REVERSE FLOW AT 1 PSI DIFFERENTIAL	LESS THAN 0.06 SCIM, [.98 SCCM]
MEDIA	GASES, NOTE 2, NOTE 4
MAX INLET PRESSURE	75 PSI, [5.2 BAR]
WETTED MATERIALS	POLYSULFONE, SILICONE
RECOMMENDED SYSTEM FILTRATION	5 MICRON



AIR-LOGIC @ DIVISION OF KNAPP MFG, INC.
 5102 DOUGLAS AVE RACINE, WI 53402
 PHONE: (262) 639-9035 FAX: (262) 639-5996 WEB: AIR-LOGIC.COM

PART/DRAWING NO.:

F2804404

DESCRIPTION:
 THREADED CHECK VALVE, #10-32

REVISION: B

DRAWN: 3/10/2021

SCALE: 5 : 1

SHEET SIZE: B

TERMS OF USE:

THIS DRAWING IS FOR INFORMATIONAL PURPOSES ONLY. AIR LOGIC MAKES NO REPRESENTATIONS OF WARRANTIES CONCERNING SUITABILITY FOR ANY PARTICULAR PURPOSE. ALL PRODUCTS SUPPLIED ARE SUBJECT TO TERMS AND CONDITIONS FOUND AT AIR-LOGIC.COM

DRAWING TAKES PRECEDENCE OVER 3D MODEL GEOMETRY

TOLERANCE: DECIMALS .00 ± .01, .000 ± .005, FRACTIONS ± 1/64
 ANGLES 1/4° UNLESS OTHERWISE SPECIFIED
 UNITS: INCHES [MILLIMETERS]