

NOTES:

1. ALL DIMENSIONS FOR REFERENCE ONLY
2. REFER TO AIR LOGIC'S POLYSULFONE APPLICATION GUIDE
3. TUBE RETENTION PRESSURE SUBJECT TO TUBING DIMENSION AND STIFFNESS
4. GASES MUST BE CLEAN AND DRY

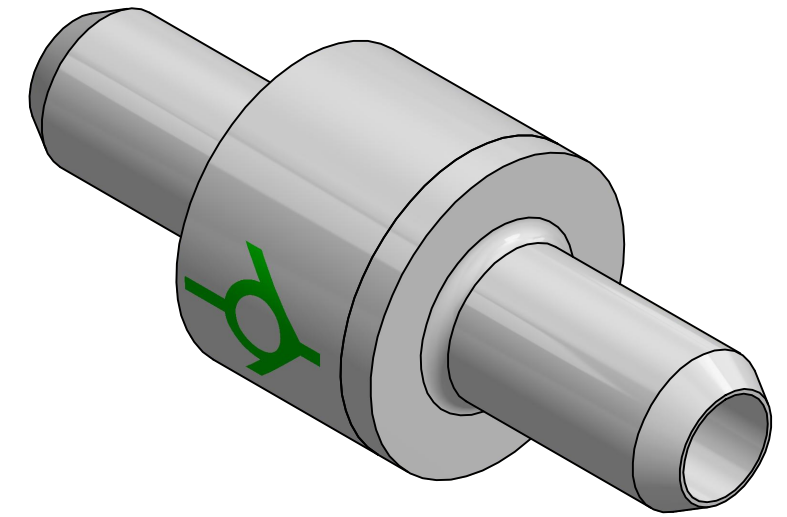
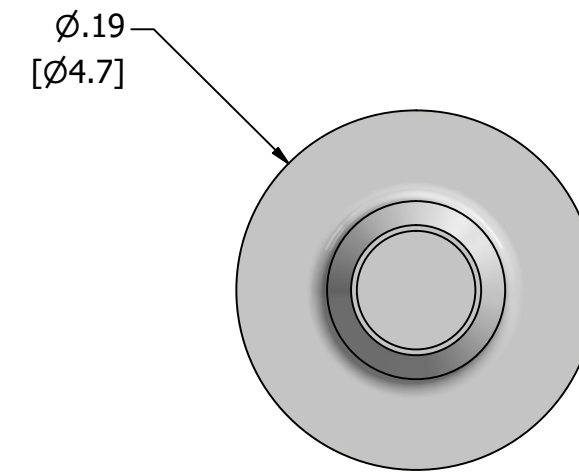
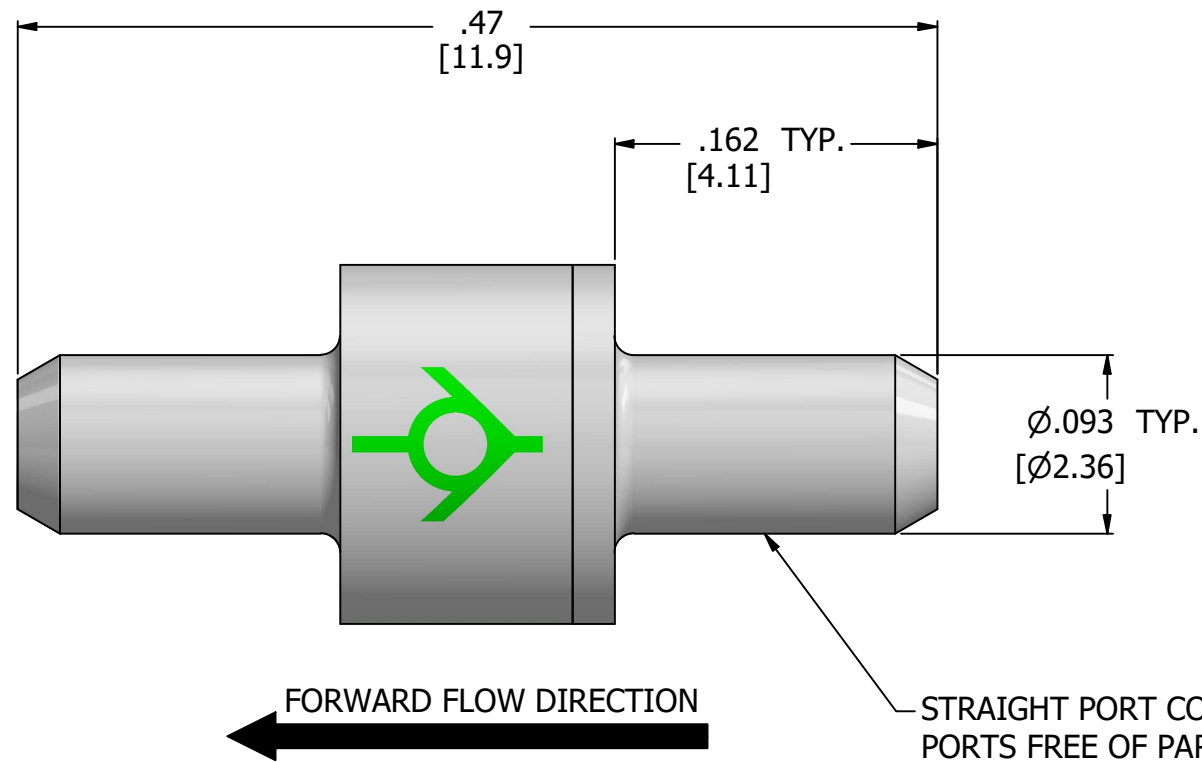

PRODUCT SPECIFICATIONS

COLOR(S)	WHITE HOUSING, GREEN PRINT
CHECK VALVE TYPE	FLOATING DISK
CRACKING PRESSURE	LESS THAN .8 inH2O
FORWARD FLOW AT 1PSI DIFFERENTIAL	0.12 SCFM
REVERSE FLOW AT 1PSI DIFFERENTIAL	LESS THAN 1.00 SCIM
MEDIA	GASES, NOTE 2, NOTE 4
MAX INLET PRESSURE	10 PSI, [689 MILLIBAR]
TYPICAL TUBE RETENTION PRESSURE	25 PSI, [1.7 BAR], NOTE 3
WETTED MATERIALS	POLYSULFONE, ACETAL
RECOMMENDED SYSTEM FILTRATION	5 MICRON



AIR-LOGIC @ DIVISION OF KNAPP MFG, INC.
 5102 DOUGLAS AVE RACINE, WI 53402
 PHONE: (262) 639-9035 FAX: (262) 639-5996 WEB: AIR-LOGIC.COM

PART/DRAWING NO.:

F2804402

DESCRIPTION:
 INLINE CHECK VALVE, 1/16" PORTS

REVISION: A

DRAWN: 3/10/2021

SCALE: 10 : 1

SHEET SIZE: B

TERMS OF USE:

THIS DRAWING IS FOR INFORMATIONAL PURPOSES ONLY. AIR LOGIC MAKES NO REPRESENTATIONS OF WARRANTIES CONCERNING SUITABILITY FOR ANY PARTICULAR PURPOSE. ALL PRODUCTS SUPPLIED ARE SUBJECT TO TERMS AND CONDITIONS FOUND AT AIR-LOGIC.COM

DRAWING TAKES PRECEDENCE OVER 3D MODEL GEOMETRY

TOLERANCE: DECIMALS .00 ± .01, .000 ± .005, FRACTIONS ± 1/64
 ANGLES 1/4° UNLESS OTHERWISE SPECIFIED
 UNITS: INCHES [MILLIMETERS]